



NICHHA

Design Cement Panel Catalogue



Top Message

Reinforcing capabilities for sustained growth with the goal of becoming a globally competitive building wall material specialist.

Significant changes are taking place in the business climate of the Nichiha Group in Japan, notably the shrinking housing market as the population declines and the rising level of activities for carbon neutrality. To build a base for sustained growth, our group is moving quickly with measures for achieving our major goals in accordance with the New Medium-term Management Plan (April 2021 to March 2024).



Narumitsu Yoshioka
President

1) A big increase in production capacity

We plan to build a flexible manufacturing infrastructure with extra capacity in order to meet growth in demand. This is needed to aim for steady market share growth and for entering new markets. Establishing this infrastructure will allow us to raise our sales volume by targeting opportunities created by demand that exceeds our forecasts. One activity is increasing the output of processes that are currently bottlenecks concerning manufacturing efficiency in Japan. Improving these processes will raise our production capacity at a much smaller cost than would be needed to build an entirely new production line. We expect this investment and other activities we have already taken to raise production efficiency to result in an increase of about 20% in the combined production capacity of our plants in Japan and the new U.S. plant.

2) Expansion outside Japan

Construction of the U.S. new plant gives us the ability to supply products in growing markets. In addition, this new plant improves our ability to develop products in a timely manner that meet the needs of customers in other markets with focus on North America. We also plan to increase our sales in other countries where we already have a presence, including China, Russia, Australia, South Korea and others. From a longer perspective, we plan to start establishing sales channels in Europe.

3) Growth in the non-residential building sector

We have developed a number of construction methods for the non-residential construction sector, including medium and high-rise buildings. Two examples are a new method using special metal brackets for siding products on buildings up to 45 meters tall and a new method for structures that are fire-resistant for one or two hours. Furthermore, we are combining these innovative construction methods with our products that are attractive and are fire and weather resistant. Our methods and products have the advantages of making construction work faster and more environmentally responsibility too. We plan to use these benefits to establish a sound position in the market for constructing non-residential buildings.

4) Growth of the metal siding business

Metal siding is widely used for newly constructed residential buildings and at renovation projects. As residential building construction declines in Japan, we anticipate steady growth of sales of metal siding for remodeling and repair work at existing residential structures. In addition, we believe there is much potential demand for metal siding in the non-residential building sector, just as there is in our core tile exterior wall panel operations. We are increasing metal siding sales activities for use at low-rise warehouses and factories, stores, and other non-residential structures. In addition, we are increasing our activities for creating new metal siding products, such as a siding for steel-frame structures that is fire-resistant for one hour. Our goal is to use our metal siding skills to enlarge this product category to more market sectors.

5) More activities for the environment, society and governance (ESG)

Our line of fiber reinforced cement sidings is highly competitive in terms of designs and performance as well as their ability to help protect the environment. For example, our core line of Moen Excelard (fiber reinforced cement siding) utilizes wood chips produced in Japan that would normally be discarded. Furthermore, these chips store carbon dioxide. As a result, the amount of CO2 sequestered in these panels is more than the CO2 generated when manufacturing them, making these panels very environmentally responsible. A recycling system of fiber reinforced cement siding is another illustration of our commitment to protecting the environment. At residential and other construction sites, we collect tile scraps for reuse in order to lower the amount of waste materials at these sites. We are promoting the use of this system by other companies too. The Nichiha Group will continue to step up a broad range of activities, such as cutting manufacturing CO2 emissions by reducing our energy intensity, in order to lower the environmental impact of all our operations.

Examples of Environmental Initiatives

“Contributing to global environmental protection with cladding panels”

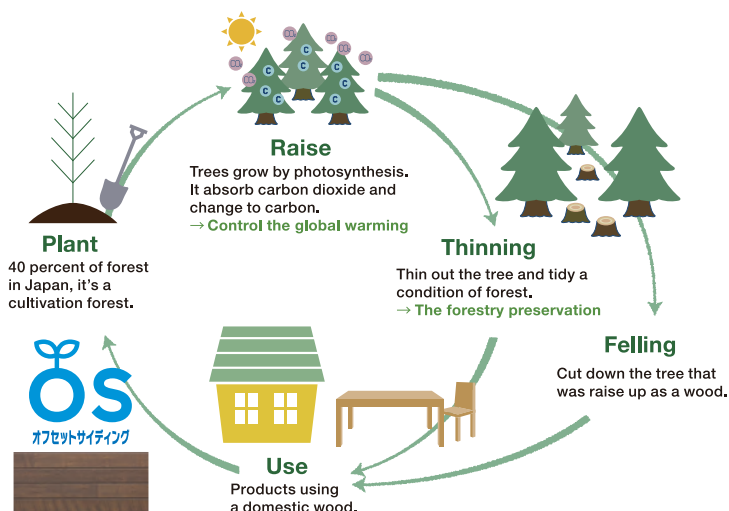

At the 17th Conference of Parties to the United Nations Framework Convention on Climate Change (COP17) in 2011, it was agreed to count the emission rate of carbon from domestically harvested timbers. It should be recorded when timber products are discarded. Therefore, exterior wall materials made with domestic lumbers are accdmitteped as storage of carbon until disposal occurs.

NICHIHA Offset Siding products contribute to the prevention of global warming through the usage of domestic wood chips in raw materials.



Offset siding is an exterior wall product made by utilizing domestic wooden chips, corresponding to a lot of our product lines.

Corporate Outline

NICHIHA CORPORATION



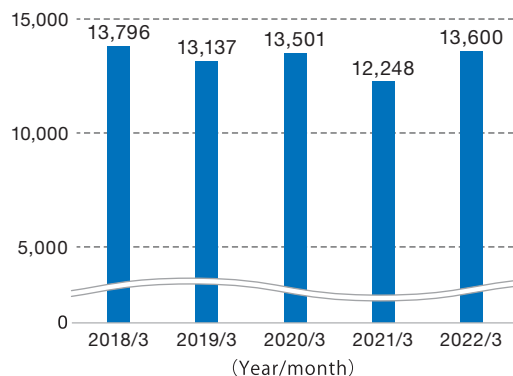

Headquarters	Mitsui-Sumitomo Bank Nagoya Bldg. 2-18-19 Nishiki, Nakaku, Nagoya, Japan
President	Narumitsu Yoshioka
Establishment	June 25, 1956
Capital	¥8,136.49 million
Common Stock Outstanding	37,324,264
Stock exchange	Prime market, Tokyo Stock Exchange Premier market, Nagoya Stock Exchange
Number of Employees	1,315 (as of March, 2021)

Consolidated sales

(Hundred million)



Corporate History

June	1956	<ul style="list-style-type: none"> Nippon Hardboard Co., Ltd. is incorporated with the goal of using wood resources efficiently. Construction of Nagoya Plant starts at Shiotomecho, Minatoku, Nagoya. 	
November	1974	<ul style="list-style-type: none"> The company begins production of fiber reinforced cement sidings. 	
April	1988	<ul style="list-style-type: none"> The company is changed its name NICHIHA Corporation. The company unifies its products under the "NICHIHA" brand name. 	
December	1996	<ul style="list-style-type: none"> The company is listed on the First Section of the Tokyo Stock Exchange. 	
May	1998	<ul style="list-style-type: none"> NICHIHA USA, Inc. is founded. 	
July	1999	<ul style="list-style-type: none"> ISO 9001 certification is granted for production of fiber reinforced cement sidings and roofing materials. 	
December	2004	<ul style="list-style-type: none"> Established "NICHIHA Decoration Building Materials (Jiaxing) Co., Ltd." in Zhejiang Province, China. 	
January	2005	<ul style="list-style-type: none"> Established "NICHIHA Decoration Fiber Cement Sidings (Jiaxing) Co., Ltd." in Zhejiang province, China. 	
April	2006	<ul style="list-style-type: none"> Established the International Business Department in charge of export and sales of products to the United States, Russia, Australia, Taiwan, and other countries and regions. The headquarters plant of NICHIHA Decoration Building Materials (Jiaxing) Co., Ltd. started operations. 	
February	2007	<ul style="list-style-type: none"> The headquarters plant of NICHIHA Decoration Fiber Cement Sidings (Jiaxing) Co., Ltd. started operations. 	
October	2007	<ul style="list-style-type: none"> NICHIHA USA, Inc. Macon Plant begins operations. 	
April	2012	<ul style="list-style-type: none"> The representative office was opened in Moscow, Russia. 	
December	2013	<ul style="list-style-type: none"> Obtained a certificate ISO14001:2004 (production of fiber cement material) (Nagoya Plant, Iwaki Plant, Shimonoseki Plant) 	
November	2014	<ul style="list-style-type: none"> Obtained a certificate ISO14001:2004 (production of fiber cement material) (NICHIHA Matex Co., Ltd Narashino Plant and Kinuura Plant, Takahagi NICHIHA Corporation Takahagi Plant) 	
December	2019	<ul style="list-style-type: none"> Obtained a certificate ISO14001: production of fiber cement material (Yatsushiro) 	

Our main products

Design Cement Panel

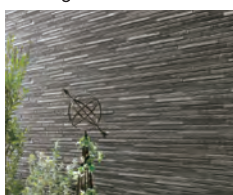

Decorative Cement Block



Metal Cladding Panel

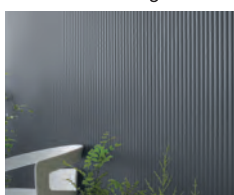

Fire-resistant Roofing Panel



Please ask us for further information on each product and any other exterior wall materials except these.

Residential (Single Family)





Residential (Multi Family)





Commercial





Public





Interior



Remodel

Before

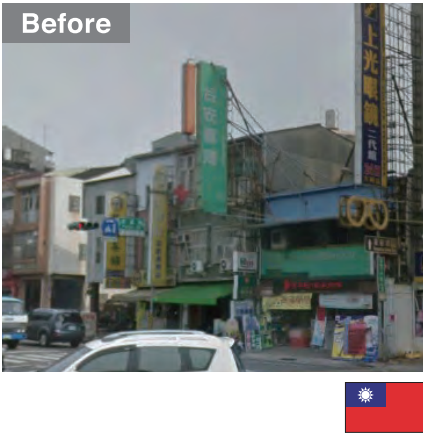

After



Before



After



Before

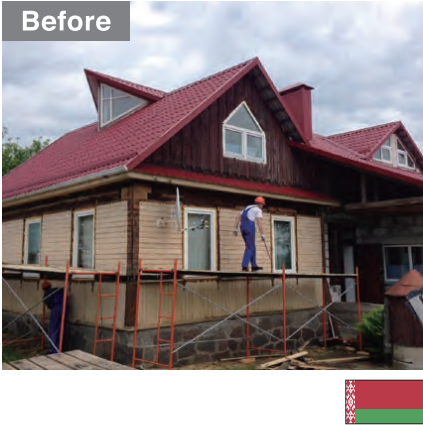

After



Basic Features of Panel

■ NICHIIHA Panel install "Dry-wall Construction"

"Dry-wall construction" is the method that fixes prefinished panels at the site. It shortens curing period for dry-wall construction differing from "Wet-wall construction" such as stucco or paint which needs water. Besides, the size of panel is big, and simple to construct and shorten the term of construction work.

■ Installation image

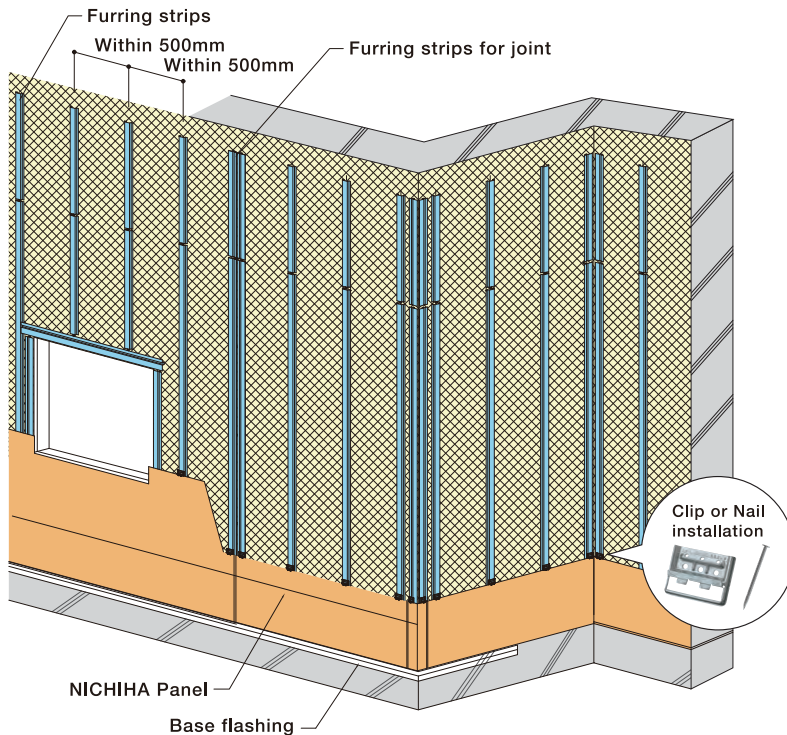

◆ Merit of Dry-wall Construction



EASY INSTALLATION

Timesaving Clip Installation System that reduces construction time and minimizes mistakes.



NO MORTAR, NO MESS

Prefinished panels that eliminate the need for messy mortar or costly masonry-skilled labor.



ANY WEATHER PRODUCT

Products that can be installed all year round.



LOW MAINTENANCE

No-fuss products. No ongoing cleaning and regular maintenance needed. Your customers get to create it then enjoy it for a long, long time.

◆ Operation of "Ventilation"

This operation makes an air layer between the panel and building paper (moisture-permeable water-proof sheet). Using this operation it can be expected to inhibit the entry of rainwater, prevent dew condensation in a wall by letting moisture be out, and block hot air in summer.

It is effective for improvement of building durability.

■ Inhibition the entry of rainwater and dew condensation

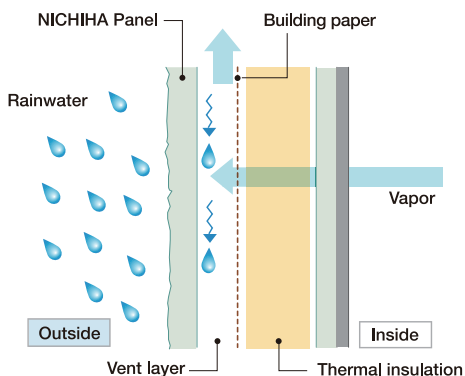

■ Block hot air in summer

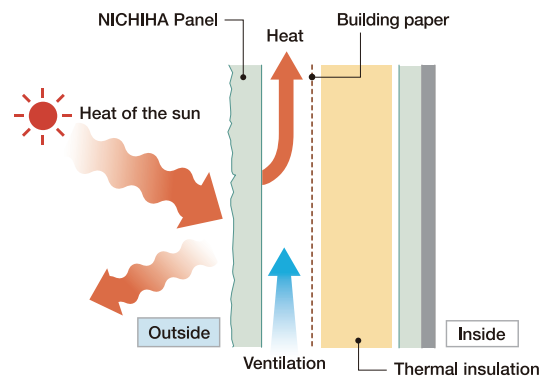

What is NICHHA design cement panel?

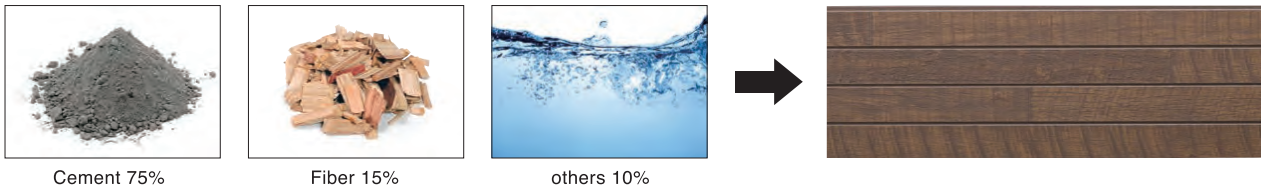

NICHHA designed panels, made primarily of cement, are exterior wall claddings manufactured according to Japanese Industrial Standard (JIS A 5422), which guarantees high quality. Furthermore, under NICHHA's philosophy of "safety is as important as product quality", NICHHA has been manufacturing products with raw materials free of asbestos since 1981. With more than 700 colors and design patterns, you can choose your own exterior wall style based on your preferences.

Standard Size

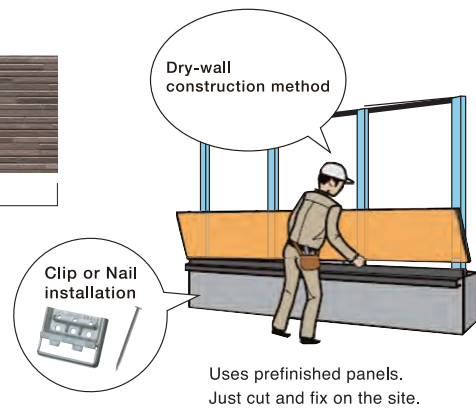
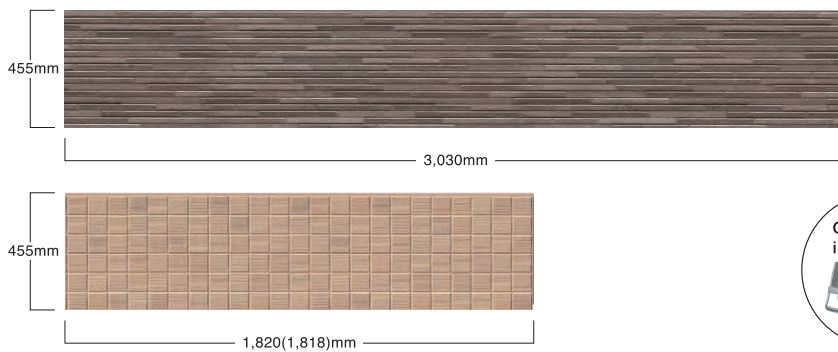

The characteristic type of product is 1,820mm (6') in length. It is a ship-lapped panel and allows you to reduce usage of sealants at joints. Furthermore, the finish looks seamless and sleek.

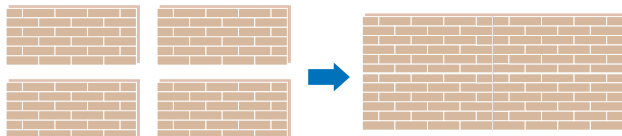

Usually side joint parts need sealants in a vertical way. However, tongue and groove panels allow reduced usage of sealants, providing for better appearance with less maintenance.

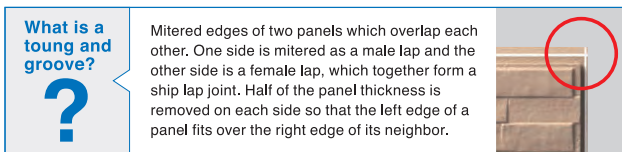

Horizontal installation with clip

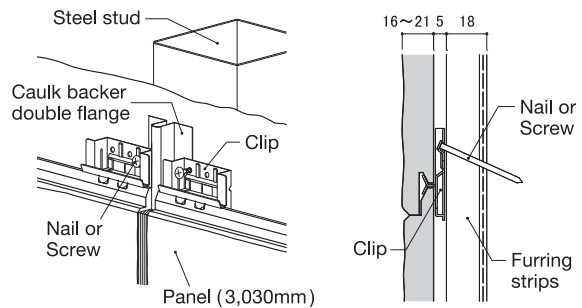

Direction suitable for panel installation

1. Vertical installation

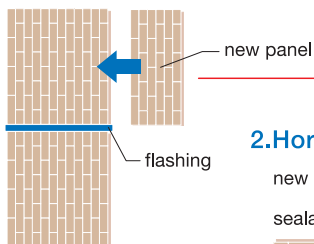

2. Horizontal installation

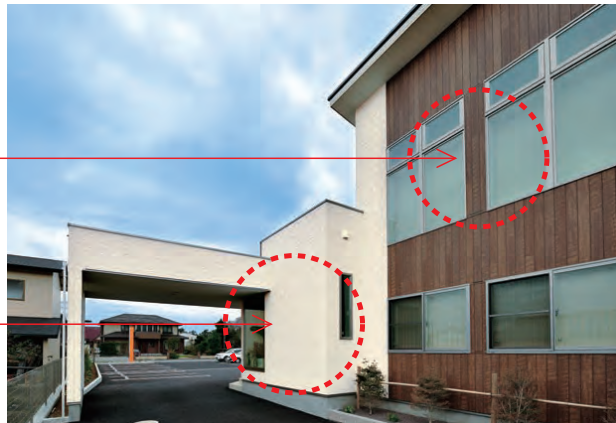
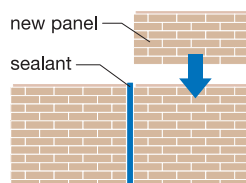

Feature of Offset siding

NICHIHA offset siding is a great material for freeze-thaw resistance, dimensional stability, and formability. It adapts dry forming process and is reinforced by wood-based ingredients. The dry forming process is a process of mixing wood-based materials and cement together with a little water and pressing the mixture in a mold.

Freeze-thaw resistance

Water contained in small air gaps in cladding panels expands when it freezes. If there isn't enough space equivalent to its expanded volume, cladding panels can't hold the pressure produced by the water's expansion, which causes frost damage. Wood materials, main ingredients of offset siding likely consist of honeycomb structures that are chained cells, like pipes together. The structures help absorb and ease pressure due to freezing.

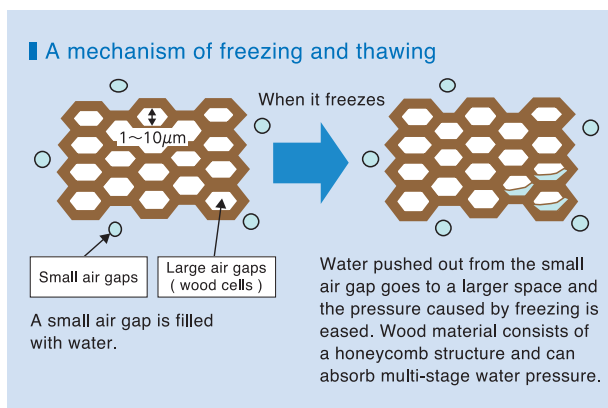

Honeycomb structures of wood cells

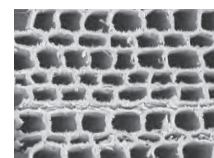

Image of a material cross section



Paint peeling and cracks may occur if cladding panels absorb excessive moisture. Offset sidings are designed to absorb the least amount of moisture as possible and to be insusceptible to the influence of moisture. The front and back sides of the panels are sealed with a protective coating. Furthermore, even after 600 cycles of weather resistance testing based on the JIS test method, paint peeling on the surface, delamination damage, and thickness changes are hardly found.

Cladding panel freeze / thaw resistance testing under JIS A 5422: After 200 cycles of weather resistance testing with panels exposed to a freezing air temperature (-20°C) and subsequent thawing in water, cladding panels should have surface peeling dimension ratio of less than 2%, remarkable delamination damage not found, and show a thickness change ratio less than 10%.

Dimensional stability

A dimensionally stable panel substrate, resistive to shrinkage due to dryness and expansion by heat and moisture absorption, is made by curing and hardening the panels immediately in a high-pressure and high-temperature autoclave. Additionally, the design specification adds further protection from the influence of moisture and dryness with sufficient paint finish on both the front and back sides of the panels.

Dimensional shrinkage test results for 5-year board exposure

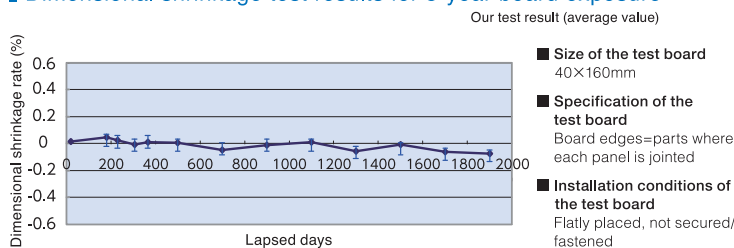

High strength

Offset siding utilizes wood materials as reinforcing fibers. Generally speaking, iron and concrete have higher performance of strength than wood, but wood bending strength is 15.4 times greater than iron and 400 times stronger than concrete, when compared to specific strength. (Specific strength is a value calculated by dividing strength by specific gravity. If specific strength is higher, we can get higher strength result even though each has the same specific gravity.)

Specific strength

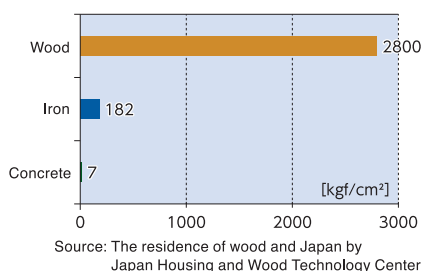

Bending fracture load

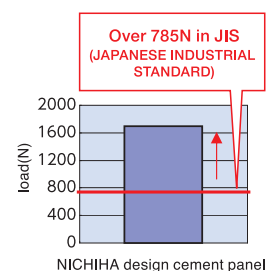

Weather Resistance

Platinum-Coating

NICHIHA recommends Platinum coatings for high weather resistant coating products.

Superior Highly Weatherable “PLATINUM-COATING” keeps maintenance low.

Our improved ultra-high-weathering paint improves durability from our past formula, making it possible to extend the ten to fifteen year repainting interval for a significant reduction in maintenance cost.

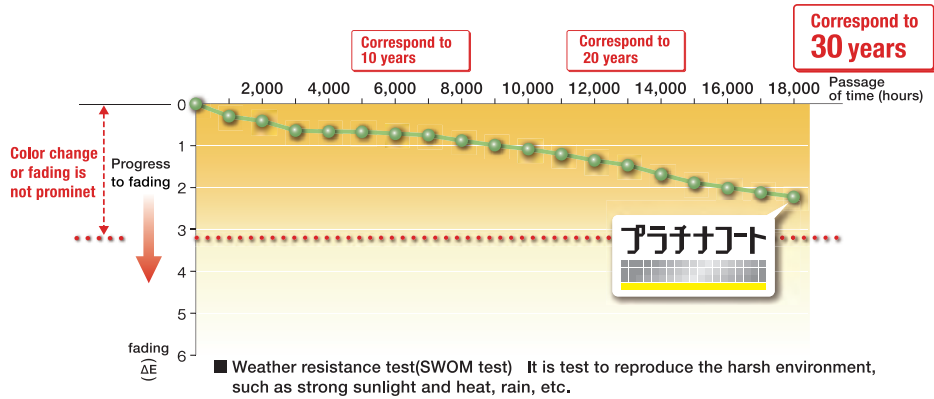

Point 1 Bonding strength is enough to guard from ultraviolet rays.

The platinum-coat has bonding energy of 435kj/mol, higher than that of ultraviolet light, which is only 410kj/mol, and thus protects the siding completely from ultraviolet damage.

Point 2 In 18,000 hours of testing to strict standards, platinum-coating maintained its appearance.

Platinum-coating has passed 18,000h of accelerated weather testing, which exposes the samples to severe natural circumstances such as strong sunlight, temperature and rain. Showing it's superior resistance to color fading and sunburn, to maintain a beautiful exterior wall for a long time.

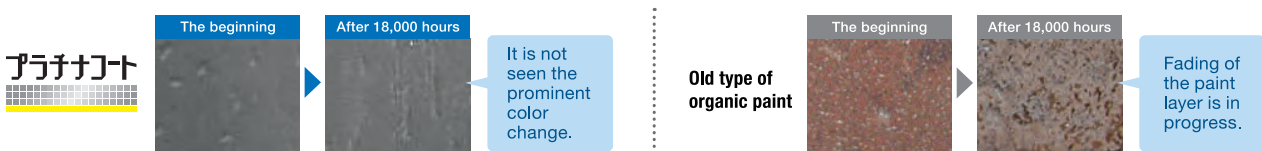

Non-asbestos Products

We developed exterior building materials completely free from asbestos with consideration for safety.

NICHIHA was quick to develop exterior building materials completely free from asbestos, a suspected carcinogen. We have ensured that all our products are completely non-asbestos since 1981. “Safety” is one of the performances. It is our unchangeable policy.

Asbestos is a naturally occurring silicate mineral. It may cause of lung cancer and mesothelioma.

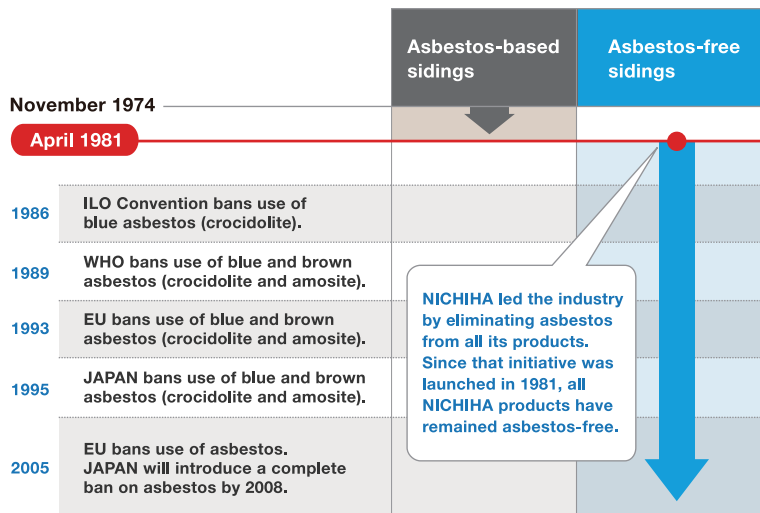

Self Cleaning "NichiGuard"



It keeps beauty of the building with self-cleaning performance which washes off the dirt by the rain.

Point 1 NichiGuard performance: a layer of water molecules on the panel prevent the dirt in the air from attaching to the siding directly. When it rains, the dirt is automatically washed off by the rain water.



NichiGuard panel

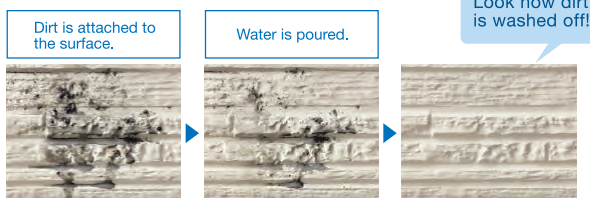

Non NichiGuard panel

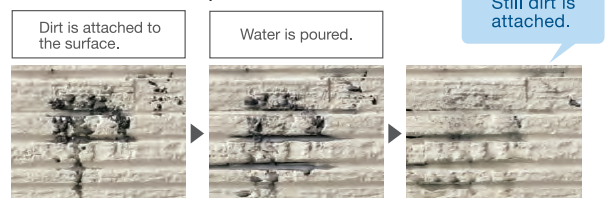

Point 2 Lasting effects even in shadowy areas or nighttime.

Point 3 The dirt prevention feature begins to work immediately after the installation.

Point 4 Formulated anti-algae and anti-fungal agent in NichiGuard products.

NichiGuard's self-cleaning function has a reduced effect on fungi and algae growth. Therefore, anti-algae and anti-fungal agents are included in the recipe to suppress their growth on the finished surface. However, their effect was tested by in-house standards only, and the anti-algae anti-fungal performance cannot be guaranteed, and may not be permanent.

NichiGuard is effective in preventing stains from exhaust gases, smoke, dusts, and soils; however, it may not show satisfactory performance in an environment with a large amount of these substances. Also, NichiGuard has less effect on rust and dirt with high density and viscosity. Please check and clean the outer wall frequently.

Type of dirt	Dirt-prevention effect
Exhaust gases, smoke, dusts, and soils	High performance
Rust and dirt with high density and viscosity	Low performance

It may not show satisfactory performance in an environment with a large amount of these substances.

Design

NICHIHA's exterior lineup features sophisticated designs and rich textures to choose from according to your needs.



The facade enhances the character of the building. Our Design cement panel can express the identity of the structure. We offer an extensive product line in realistic textures and color patterns.

Designer's Series

New series that is perfectly blended with beauty and durability. Expanded possibilities for space creation.

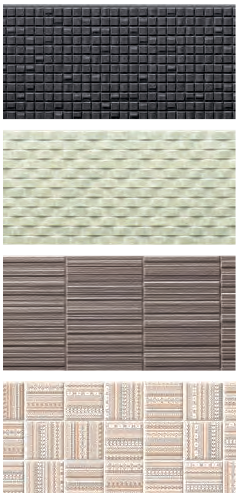

Stone

Natural stone's delicate visual impression and natural hues are realistically presented.



Brick / Tile

Luxurious design and sophisticated colors, will give the upgraded appearance.



Wood / Ribbed

Wood design create a natural impression and ribbed lines modern one.

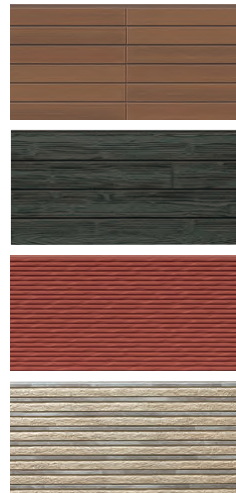

Flat

Product lineup for matching all types of design, Traditional, Western, Classic, and Modern style, etc.

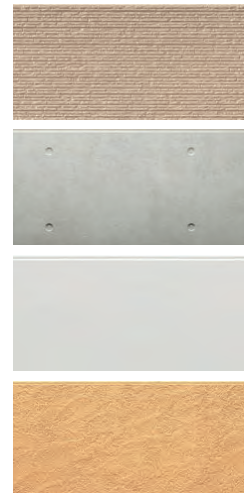

Quick installation Flow

1. Installation of furring strips and building paper



2. Installation of corner trim

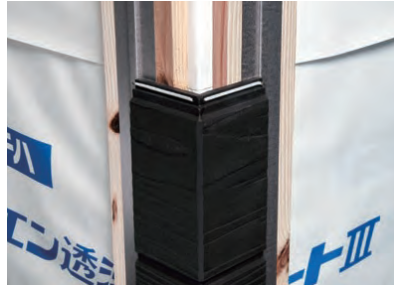

3. Cutting of panel



4. Fastening panels



5. Install panels from the bottom of the wall to the top



6. Sealant work



1. First of all, frame the wall assembly before panels can be installed (Wood studs or metal studs) and install a building paper.
2. Next, install corners.
3. Cut panels to a desired length.
4. Install panels from the bottom of the wall to the top. Panel edges have self-sealing tongue and groove joints. Appropriate joint clips are installed at vertical joints.
5. Continue installing panels from the bottom of the wall to the top.
6. Complete the installation after applying sealant to joints around openings.



This flow chart is just an overview. The installation method is different depending on building types, each country's building codes and regulations, and other factors between panel types. Please contact us for further information.

◆ Installation hardware requirements for NICHHA standard installation method

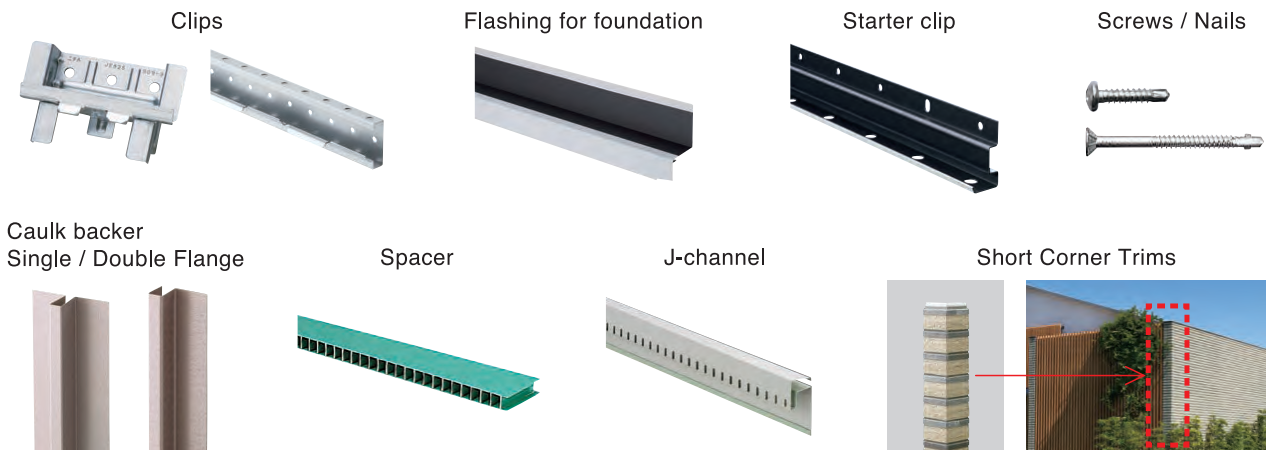



Main prohibited matters on the installation

Do not use siding on the following parts and by the installation method. It may cause failures.

Caution

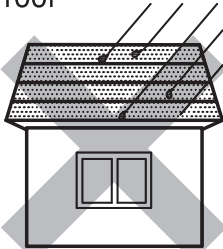
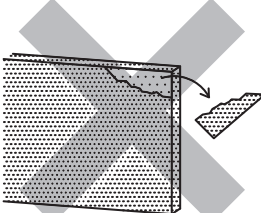
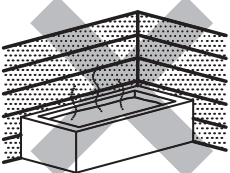
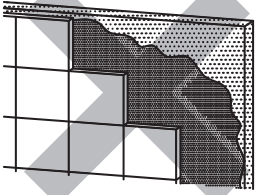
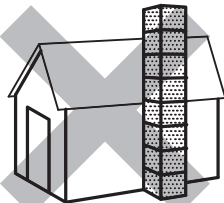

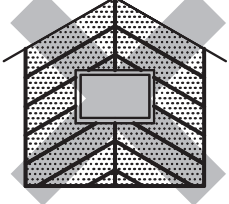
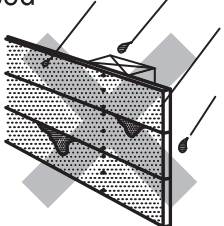
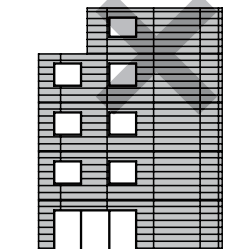
<p>1 Use on gable parapet roof</p> <p>Compared to vertical walls the environmental conditions are severe, causing deterioration of coatings, frost damage, and leaking water.</p> <p>➡ Use roofing.</p> 	<p>6 Installation of cement stucco with thick coating (including mortar painting)</p> <p>Paints with thick coating are lack of adhesion strength, causing abrasion and other failures.</p> 
<p>2 Walls which are constantly exposed to water, such as bathroom walls</p> <p>The temperature and the humidity are high and it is directly splashed with water, causing warping, frost damage, deterioration of strength, and crack.</p> 	<p>7 Direct application to siding such as tiles</p> <p>Crack and abrasion of tiles may occur.</p> 
<p>3 Installation on chimneys</p> <p>Siding absorbs water occurred in the smokestacks from the back sides as well as the deterioration by heat. It causes warpage and frost damage.</p> 	<p>8 Random installation of siding</p> <p>Please don't install panels randomly (mixed use of horizontal and vertical installation), which can result in safety and performance issues.</p> 
<p>4 Installation to high-temperature places such as a fireplace</p> <p>On the high-temperature places, water in siding is dried up, resulting in the shrinkage and cracks.</p> 	<p>9 Oblique installation</p> <p>Cause of performance issues (Water intrusion).</p> 
<p>5 Fences of one-side walls with the backside exposed</p> <p>The backsides of siding are finished only with sealers. The repetition of water absorption from backsides and dryness cause warping and other failures.</p> <p>➡ Finish the backside with walls and install copings to the upper parts.</p> 	<p>10 Height limitation for panel installations</p> <p>Basically do not use on walls of more than 13m (45') in height.</p> 

Main prohibitions are like this, but other items may also be undertaken depending on each country's laws, rules, regulations, ordinances, and construction conditions, etc. Please contact us for further info.

Production System

Production Bases in Japan

Our philosophy is to locate our production sites as close as possible to customers. We also enhance the production that is environmentally friendly.

We have 9 production bases in Japan including group companies. At each plant, we continue “Kaizen” in our production technology.

Our passionate engineers get involved in strict quality controls through the whole manufacturing process from raw materials to final products.

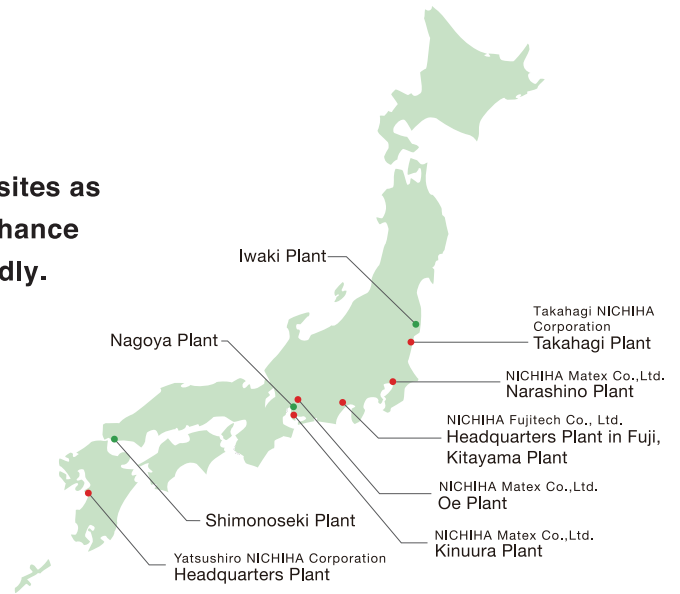

Nagoya Plant



Located close to the Port of Nagoya, our Nagoya Plant features the vast grounds and large scale befitting a main plant. The plant was designed with consideration for the environment, too as exemplified by its pulverized-coal-fired private power generation boiler, the first such plant to be installed in Japan.

Location	Nagoya, Japan
Scale	Site area: 242,400 square meters Floor area: 141,400 square meters
Plant certifications	Japan Industrial Standards (JIS) Certification ISO9001:2008 Certification ISO14001:2004 Certification

International Production Framework

NICHIIHA USA, Inc. Macon Plant



Location	Macon-city, Georgia, USA
Scale	Site area: 240,200 square meters Floor area: 37,900 square meters

NICHIIHA Decoration Building Materials (Jiaxing) Co., Ltd. Headquarters Plant



Location	Jiaxing-city, Zhejiang Province, China
Scale	Site area: 27,000 square meters Floor area: 8,200 square meters

NICHIIHA Decoration Fiber Cement Sidings (Jiaxing) Co., Ltd. Headquarters Plant



Location	Jiaxing-city, Zhejiang Province, China
Scale	Site area: 100,400 square meters Floor area: 26,000 square meters

Introduction of web site

NICHIHA web site (in English), it has more information (products, photo gallery, installation, etc) besides in this catalogue. Please check and see it, too.

Since material handling and installation vary from country to country, For the US, Canada, Mexico, China, Russia and CIS countries and areas, please refer to the information provided by the local web site of NICHIHA.

NICHIHA web site (in English)

There is an information about products, photo gallery, installation, etc.

▶ <http://www.nichiha.co.jp/global/index.html>

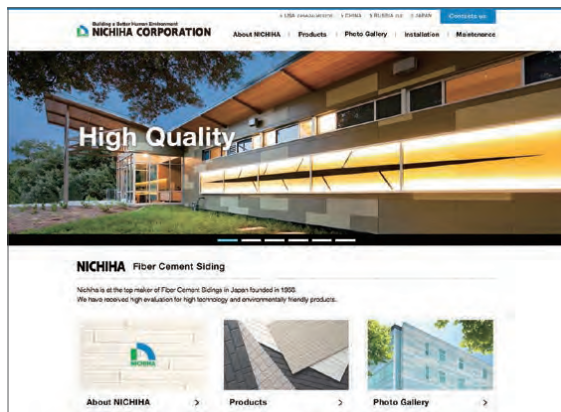

NICHIHA web site (in Japanese)

A variety of information about NICHIHA in Japanese.

▶ <http://www.nichiha.co.jp>



Web site of an overseas edition for each part

USA CANADA · MEXICO

▶ <http://www.nichiha.com>



CHINA

▶ <https://www.nichiha.com.cn>



RUSSIA CIS

▶ <http://www.nichiha.ru>





■ NICHHA Internet Homepage Address (in English)
<http://www.nichiha.co.jp/global/index.html>

NICHHA Design Cement Panel

